

Aviation Fabricators
805 North Fourth Street
Clinton MO 64735

Document No: AF-617
Revision: (B)
Date: October 1, 2019

INSTRUCTIONS FOR CONTINUED AIRWORTHINESS

For

High Density Seat Installations

Document No.: AF-617

Revision "B"

Revision Date: 10/01/19

Applicable to:

**Textron models: 65, A65, 65-80, 65-B80, 70, 65-88,
65-90, 65-A90, B90, C90, C90A, C90GT, E90, F90, 99, 99A, A99,
A99A, B99, C99, 100, A100, A100C, B100, 200, 200C, 200CT,
200T, A200, A200C, A200CT, B200, B200C, B200CT, B200T,
B200GT, B200CGT, 300, B300, B300C, 300LW**

Modified by FAA STC's SA2774CE, SA2775CE, SA2776CE & SA2777CE

The information in the Instruction for Continued Airworthiness is FAA accepted material and complies with 14 CFR 23.1529, Instructions for Continued Airworthiness. It supersedes or adds to that provided in the Maintenance Manual for the Beechcraft King Air Series Aircraft, only where covered in the items contained herein. For limitations and procedures not contained in the Supplement, consult the Component Maintenance Manual, or other approved airplane data.

REVISION PAGE

Document Title: Instructions for Continued Airworthiness

Prepared By: Todd Pogue

Updates to the ICA will be made by Aviation Fabricators Inc. Updates will be listed in the log of revisions and the effective pages will be listed below.

Log of Revisions				
REV. NO.	EFFECTED PAGE(S)	DESCRIPTION	DATE	APPROVED BY
IR	All	Initial Release	09-25-15	JRL
A	All	*Added new P/N's 32-0450, 32-0451, 32-0452, 32-0453, 32-0456, 32-0457, 32-0458, 32-0459, 32-0460, 32-0461, 32-0462, 32-0463, 32-0464, 32-0465, 32-0466, 32-0467, 32-0468, 32-0469, 32-0470, 32-0471, 32-0472, 32-0473, 32-0474, 32-0475, 32-0476, 32-0477, 32-0478, 32-0479, 32-0480, 32-0481, 32-0482, 32-0483, 32-0484, 32-0485, 32-0486, 32-0487 to Section 1.0 *Updated Figures 1.0D & 1.0F *Added Figures 1.0H, 1.0J, and 1.0K *Updated Section 5.0 for all new P/N's *Added info on new "FWD Facing Only" and "AFT Facing Only" Placards in Section 8.0 *Added "Headrest to be Extended" Placard in Section 8.0	07-07-16	JRL
B	14	*Added Figure 1.0L for Underseat Storage Bracket, p. 14 *Added Note 4 for Underseat Storage Bracket Placard to Section 8.0, p. 21	10-01-19	JRL

Per the requirement of Appendix G of 14 CFR Part 23 paragraph G23.1 (c), the changes made to the ICA by the applicant will be distributed via mail by means of paper copy.

TABLE OF CONTENTS

INSTRUCTIONS FOR CONTINUED AIRWORTHINESS	1
REVISION PAGE	2
TABLE OF CONTENTS	3
1.0 INTRODUCTION	5
2.0 INSPECTION REQUIREMENTS AND OVERHAUL SCHEDULE	12
3.0 DIMENSION AND ACCESS	17
4.0 LIFTING AND SHORING	17
5.0 LEVELING AND WEIGHING	17
6.0 TOWING AND TAXIING	18
7.0 PARKING AND MOORING	18
8.0 PLACARDS AND MARKINGS	19
9.0 SERVICE INFORMATION	21
10.0 AIRWORTHINESS LIMITATIONS	23

ABBREVIATIONS AND DEFINITIONS

Abbreviations	Definitions
AML	FAA Approved Model List (AML)
Detailed Inspection (DET)	An intensive examination of a specific item, installation or assembly to detect damage, failure or irregularity. Available lighting is normally supplemented with a direct source of good lighting at an intensity deemed appropriate. Inspection aids such as mirrors, magnifying lenses, etc. may be necessary. Surface cleaning and elaborate access procedures may be required.
FAA	Federal Aviation Administration
FAA MIDO	FAA Manufacturing Inspection District Office
General Visual Inspection (GVI)	A visual examination of an interior or exterior area, installation or assembly to detect obvious damage, failure or irregularity. This level of inspection is made from within touching distance unless otherwise specified. A mirror may be necessary to enhance visual access to all exposed surfaces in the inspection area. This level of inspection is made under normally available lighting conditions such as daylight, hangar lighting, flashlight or droplight and may require removal or opening of access panels or doors. Stands, ladders or platforms may be required to gain proximity to the area being checked.
ICA	Instructions for Continued Airworthiness
Special Detailed Inspection (SDI)	An intensive examination of a specific item, installation , or assembly to detect damage, failure or irregularity. The examination is likely to make extensive use of specialized Inspection Techniques and/or equipment. Intricate cleaning and substantial access or disassembly procedure may be required.
STC	Supplemental Type Certificate

1.0 INTRODUCTION

The purpose of this Maintenance Manual Supplement and Instructions for Continued Airworthiness (ICA) is to provide the maintenance technician with the information necessary to ensure the continued airworthiness of the Aviation Fabricators high density seat installations, for seats when installed in accordance with Aviation Fabricators design data included on STC Data Lists AF-151, AF-150, AF-149, and AF-148 and per Supplement Type Certificates (STC's) SA2774CE, SA2775CE, SA2776CE, & SA2777CE.

Modifications to an aircraft obligates the operator to include the maintenance information provided by this document into the operators aircraft Maintenance Manual and operator's aircraft scheduled maintenance program. This document defines supplementary maintenance operations and frequencies recommended by Aviation Fabricators Inc., to ensure the aircraft's airworthiness.

The information contained herein addresses the requirements specified in 14 CFR 23.1529, Instructions for Continued Airworthiness and supplements the basic Airplane Maintenance Manual only in those areas listed as pertains to the installation of the high density seats, as installed per the Aviation Fabricator STC Data Lists AF-151, AF-150, AF-149, and AF-148. For limitations and procedures not contained in this supplement, consult the basic Airplane Maintenance Manual.

DATA

All information to support the continued airworthiness of this modification is contained in:

STC's SA2774CE, SA2775CE, SA2776CE, SA2777CE.
STC Data Lists: AF-151, AF-150, AF-149, and AF-148.

Installation: STC Data List: AF-151 for STC SA2774CE
AF-150 for STC SA2775CE
AF-149 for STC SA2776CE
AF-148 for STC SA2777CE

See document number: AF-614 for 200 & B200 Series Aircraft
AF-615 for 300 Series Aircraft
AF-616 for B300 Series Aircraft
AF-618 for 90 Series Aircraft
AF-619 for 99 & 100 Series Aircraft

Parts: Refer to P/N's 32-0436, 32-0437, 32-0442, 32-0443, 32-0450, 32-0451, 32-0452, 32-0453, 32-0456, 32-0457, 32-0458, 32-0459, 32-0460, 32-0461, 32-0462, 32-0463, 32-0464, 32-0465, 32-0466, 32-0467, 32-0468, 32-0469, 32-0470, 32-0471, 32-0472, 32-0473, 32-0474, 32-0475, 32-0476, 32-0477, 32-0478, 32-0479, 32-0480, 32-0481, 32-0482, 32-0483, 32-0484, 32-0485, 32-0486, and 32-0487 per respective drawings as listed on STC Data Lists AF-151, AF-150, AF-149, and AF-148.

The high density seat is a self-contained complete assembly that mounts anywhere in the cabin to the existing seat track, using standard fittings, in accordance with FAA approved floor plans.

Design Change Control

All data and changes to the parts and assemblies will be tracked per STC Data Lists AF-151 Rev X, AF-150 Rev T, AF-149 Rev T, and AF-148 Rev T or later FAA approved revisions.

Applicable Aircraft

Textron models: 65, A65, 65-80, 65-B80, 70, 65-88, 65-90, 65-A90, B90, C90, C90A, C90GT, E90, F90, 99, 99A, A99, A99A, B99, C99, 100, A100, A100C, B100, 200, 200C, 200CT, 200T, A200, A200C, A200CT, B200, B200C, B200CT, B200T, B200GT, B200CGT, 300, B300, B300C, 300LW.

High Density Seat

P/N's 32-0436 (Shown), 32-0437 (Opposite), 32-0450, 32-0451, 32-0456, 32-0457, 32-0458, 32-0459, 32-0460, 32-0461, 32-0462, 32-0463, 32-0470, 32-0471, 32-0476, 32-0477, 32-0480, 32-0481, 32-0482, 32-0483

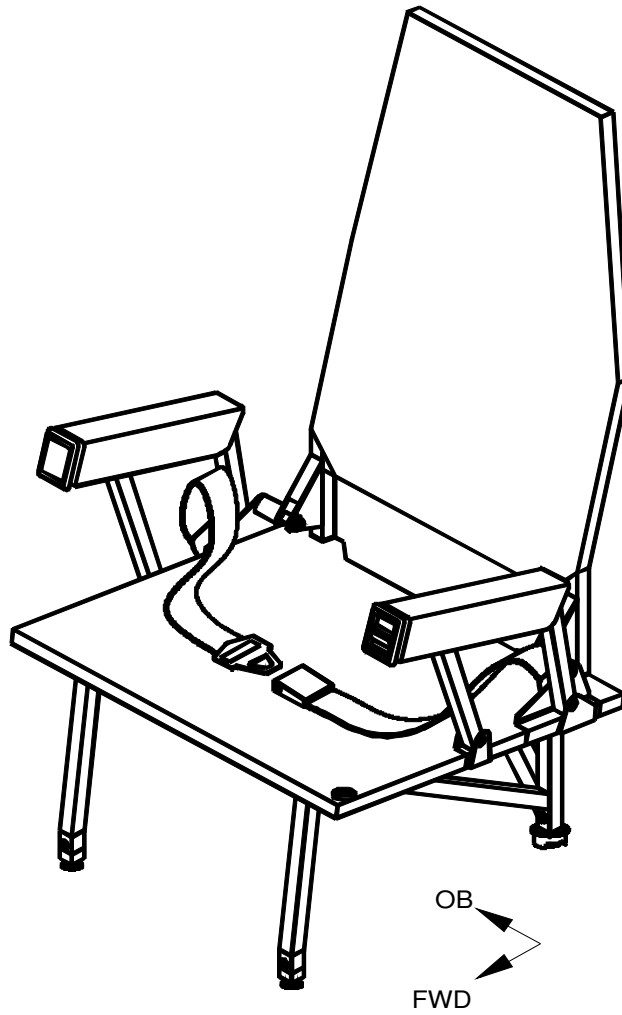

Figure 1.0A

High Density Seat for Aircraft with Armrails

P/N's 32-0442 (Shown), 32-0443 (Opposite), 32-0452, 32-0453, 32-0464, 32-0465, 32-0466, 32-0467, 32-0468, 32-0469, 32-0472, 32-0473, 32-0474, 32-0475, 32-0478, 32-0479, 32-0484, 32-0485, 32-0486, 32-0487

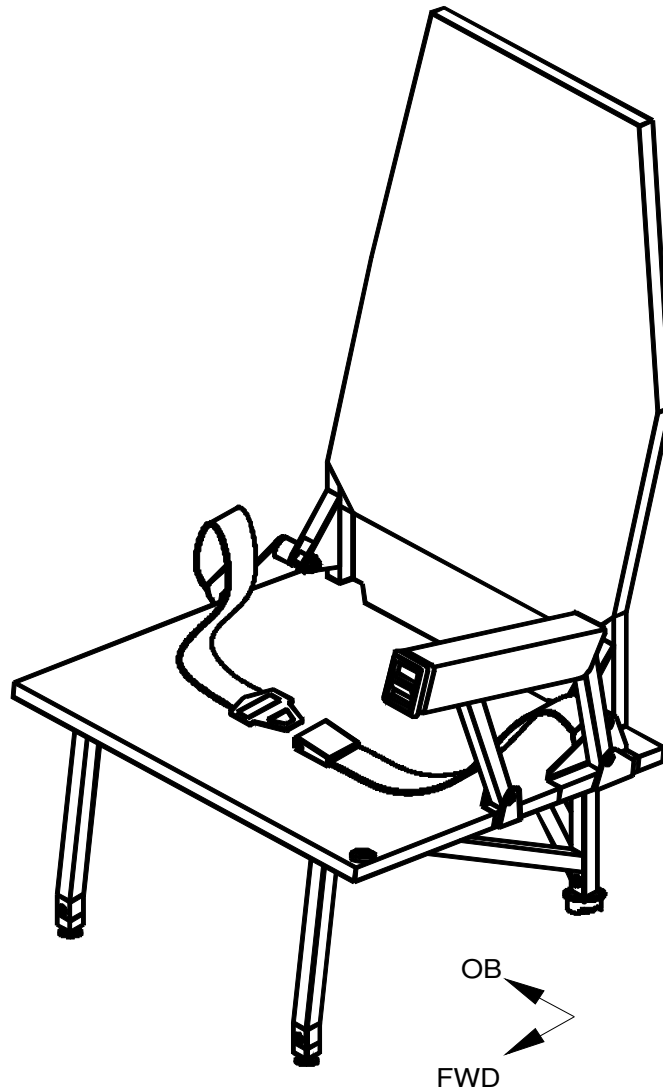

Figure 1.0B

Foot Attachment & Installation

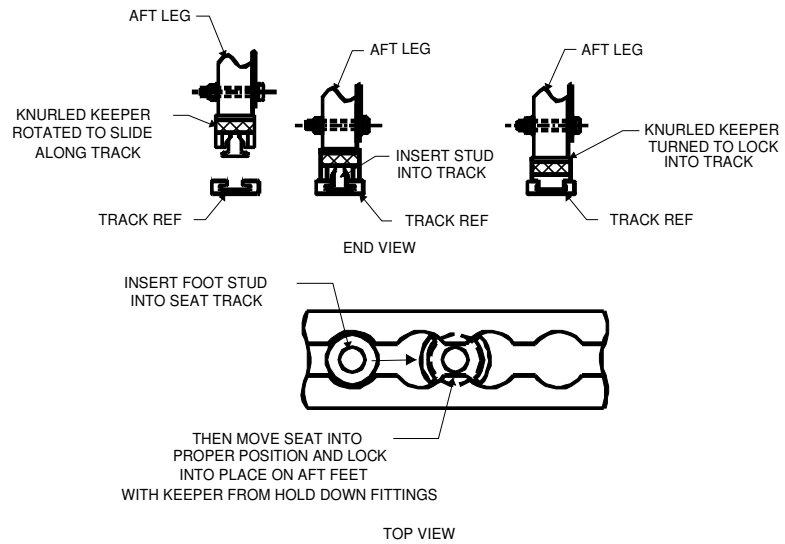
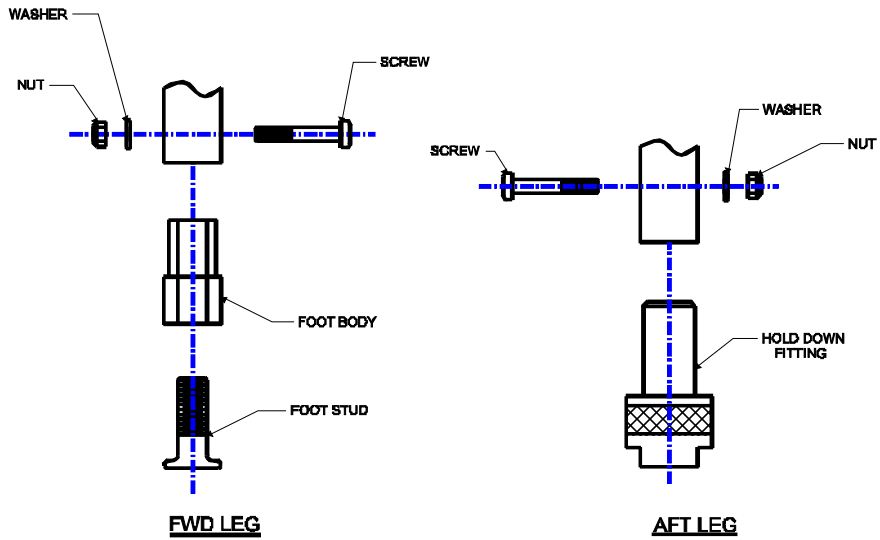

Figure 1.0C

Inboard Armrest and Seat Belt Attachment

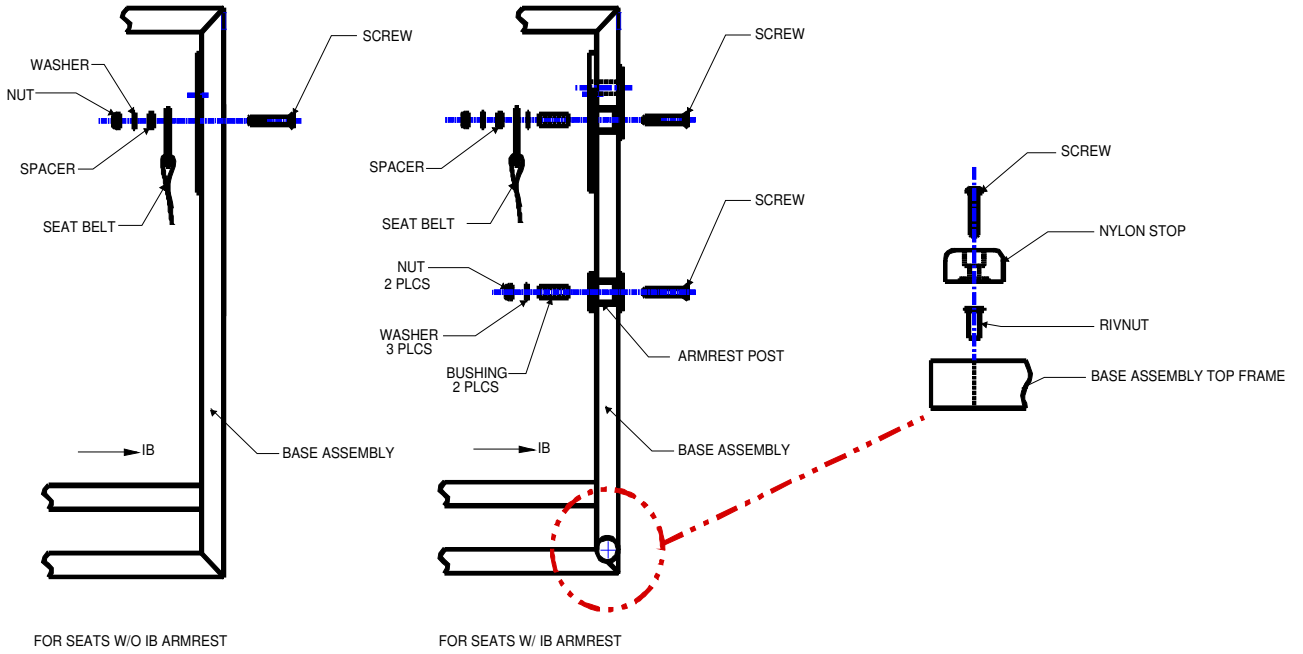

Figure 1.0D

Outboard Armrest and Seat Belt Attachment

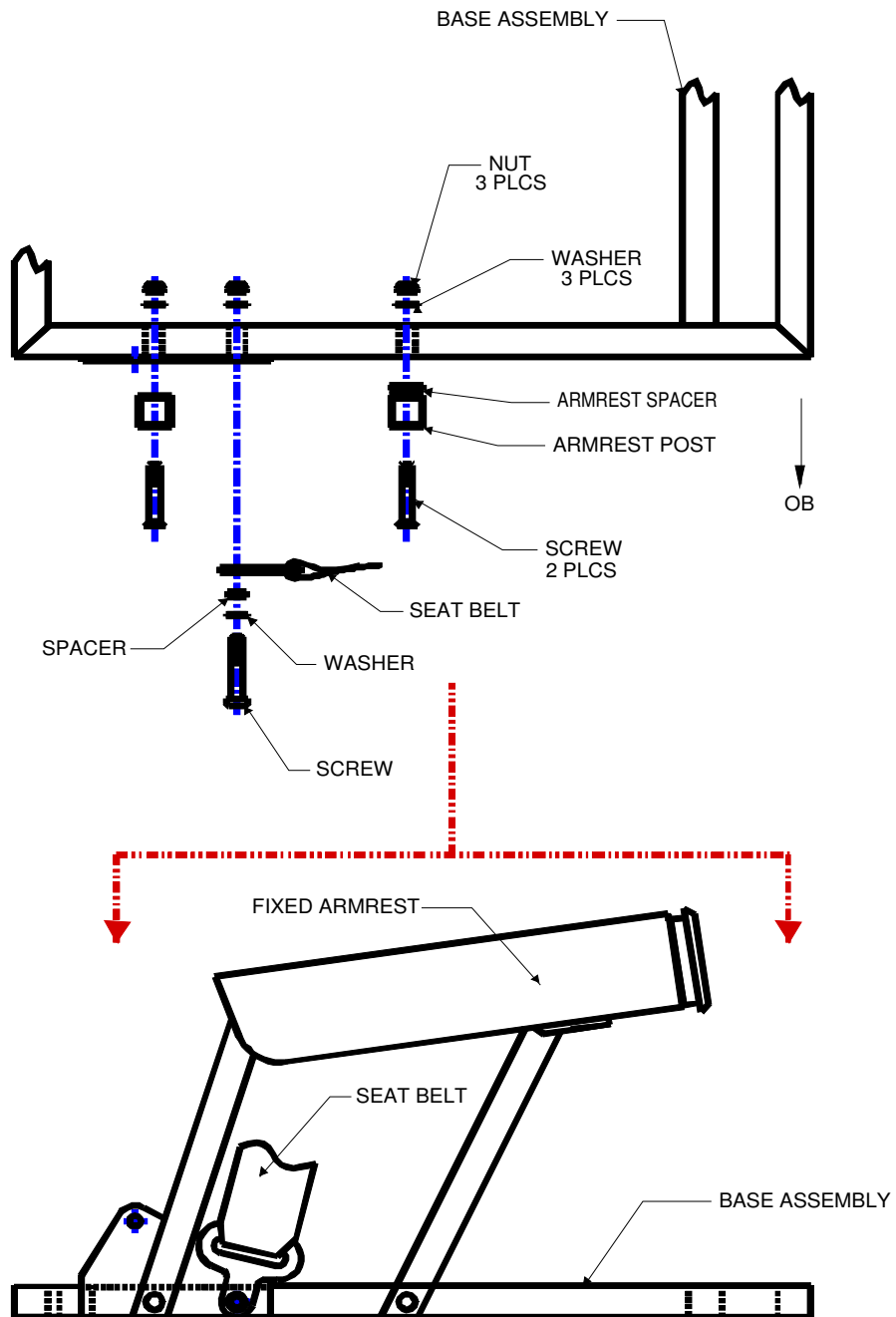

Figure 1.0E

Cushions

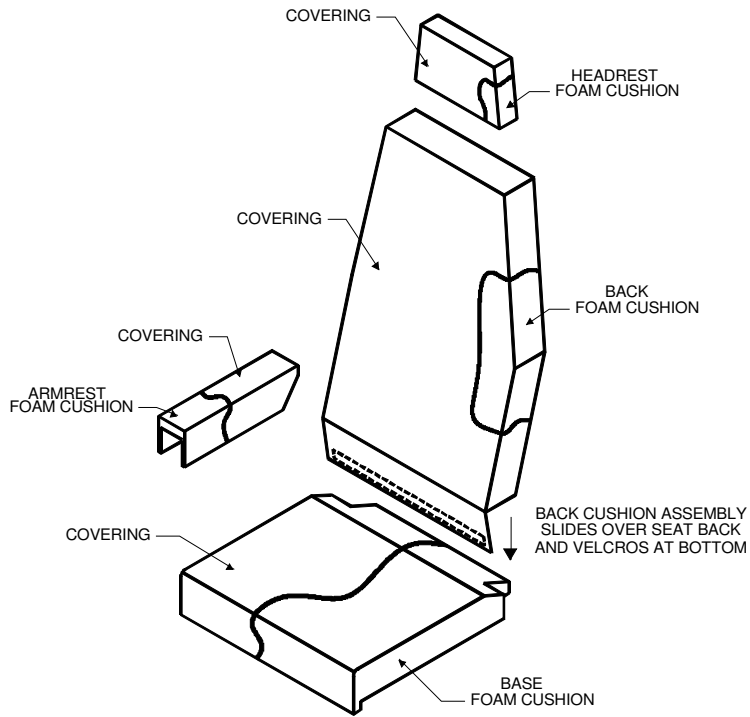

Figure 1.0F

Optional Lifevest Pouch Attachment

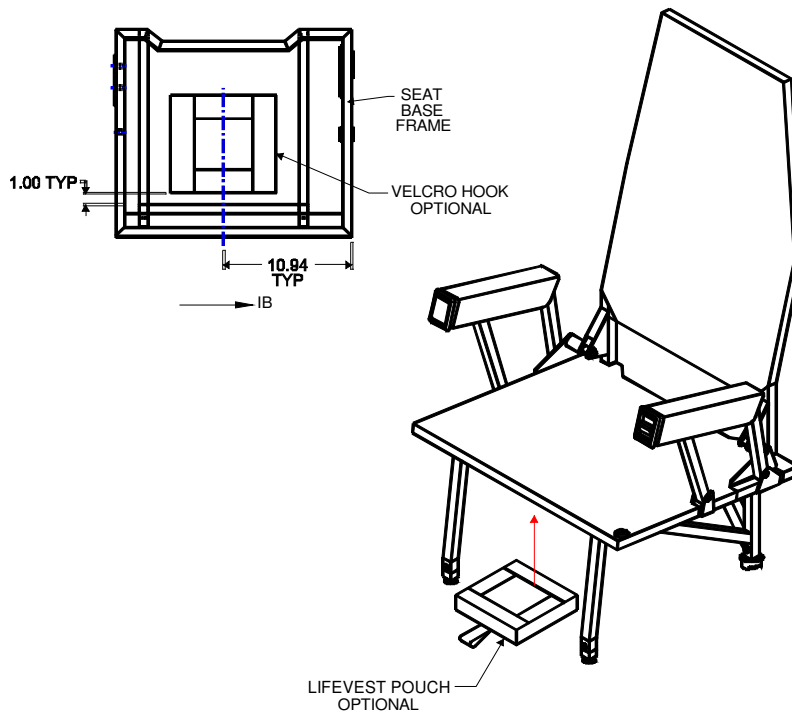

Figure 1.0G

Headrest Installation

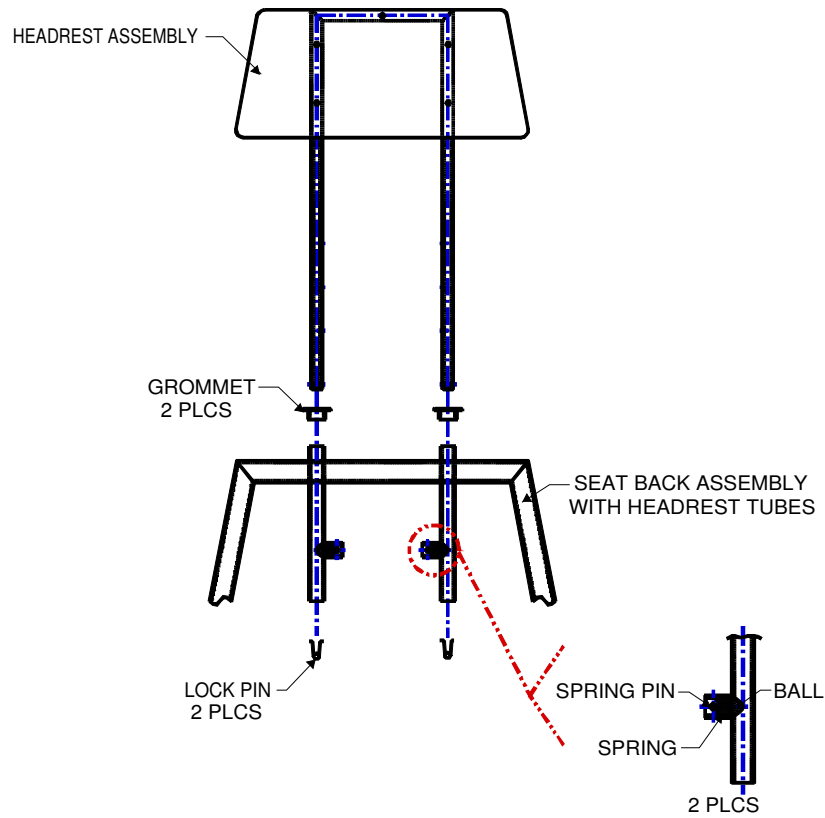

Figure 1.0H

Seat Belt Installation on Reclining Seats

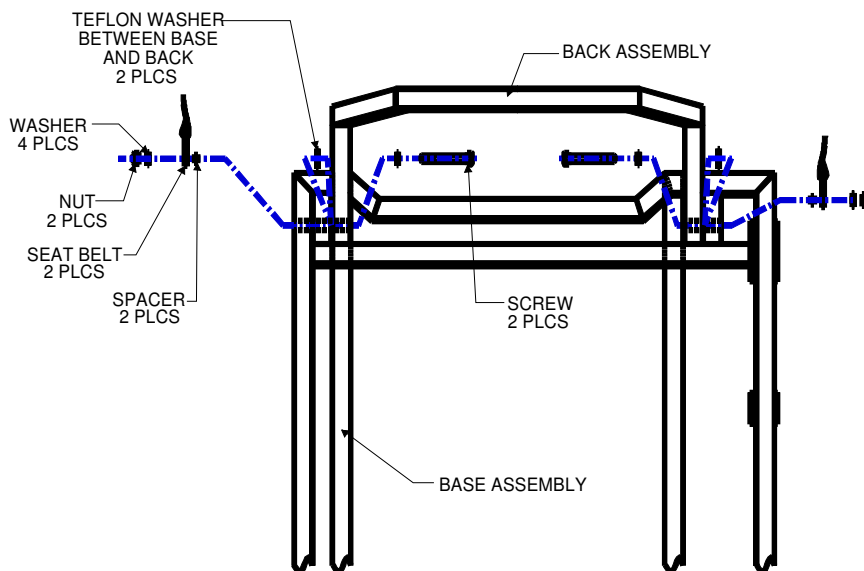

Figure 1.0J

Actuator Installation on Reclining Seats

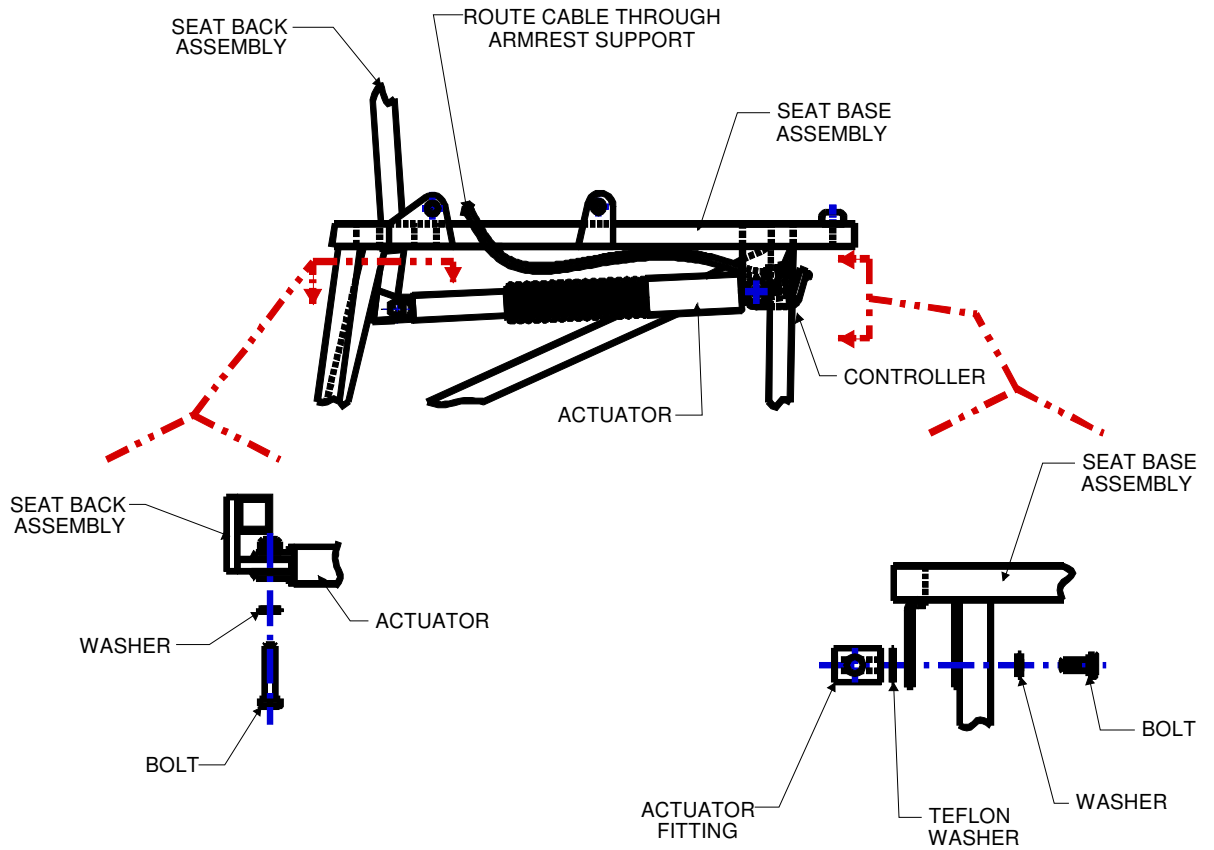

Figure 1.0K

Underseat Storage Bracket

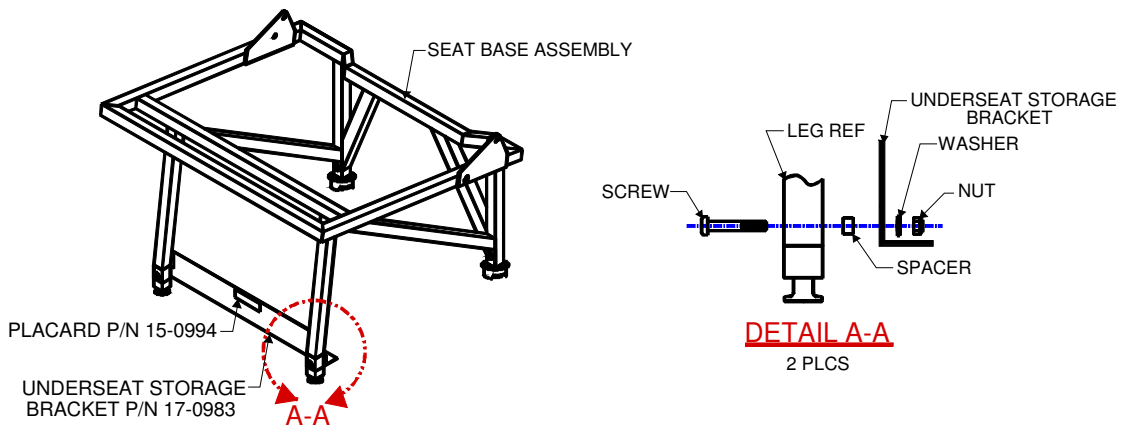

Figure 1.0L

2.0 INSPECTION REQUIREMENTS AND OVERHAUL SCHEDULE

1. To comply with 14 CFR 23.1529, continue the high density seat and restraint system(s) on the same inspection and maintenance schedule used per the applicable Beechcraft Maintenance Manual for seats.
 - a. The new seat assembly and seat belt require no service other than inspection at normal Phase 4 inspection schedule of 800 hours or 24 months whichever occurs first.
 - b. Perform a detailed visual inspection of each bottom and back cushion and cover to detect apparent or obvious defects, deterioration in the form of wear, tears, rips, punctures or irregularities that cause the cushion assembly to become worn or distorted. Replace the cushion assembly if this cover does not fit properly or the cushion develops a “lumpy” or irregular feel.
 - c. Perform a detailed visual inspection of each seat frame assembly including weld joints, diaphragm, fasteners and anchors, track fittings, and restraint systems to detect apparent or obvious defects, corrosion, cracks, large deformations (permanent deformation in frame tubes more than $\frac{1}{4}$ the overall thickness of the tube diameter), irregularities that cause the frame assembly and/or anchor/fitting to become distorted and not fit into the intended seat track/anchor locations. If deformities are found, the seat frame assembly must be removed from the aircraft and returned to Aviation Fabricators for repair or replacement.

2. Inspection Time Limit for high density seat assemblies:

Phase 4 inspection at 800 hours or 24 months whichever occurs first for the seat assembly and restraint systems

Task Code			Schedule	Date	Mech	Insp
AFI-100	a.	Inspect for damage to upholstery.				
AFI-101	b.	Inspect safety belts for wear, cuts, fraying, damage, and deterioration.				
AFI-102	c.	Inspect safety belt attachment fittings for wear and damage				
AFI-103	d.	Inspect foot fittings for damage, security, and function.				
AFI-104	e.	Inspect seat frame for damage, and corrosion.				
AFI-105	f.	Inspect seat back attaching points for wear and damage.				
AFI-106	g.	Inspect overall seat for fit and function.				

A. Add the new high density and restraint system on the same inspection and maintenance schedule used per the applicable Beechcraft Maintenance Manual for seats.

3.0 DIMENSION AND ACCESS

The installation of the high density assembly does not change the dimensions of the aircraft or alter the access to any existing aircraft system.

4.0 LIFTING AND SHORING

No change.

5.0 LEVELING AND WEIGHING

Maximum Allowable Seat Weight = 45 lbs

P/N	Weight (lbs)*
32-0436	19.5
32-0437	19.5
32-0442	18.0
32-0443	18.0
32-0450	24.0
32-0451	24.0
32-0452	22.5
32-0453	22.5
32-0456	20.5
32-0457	20.5
32-0458	16.0
32-0459	16.0
32-0460	21.0
32-0461	21.0
32-0462	17.5
32-0463	17.5
32-0464	16.5
32-0465	16.5
32-0466	19.5
32-0467	19.5
32-0468	18.0
32-0469	18.0
32-0470	22.0
32-0471	22.0
32-0472	20.5
32-0473	20.5
32-0474	22.0
32-0475	22.0
32-0476	21.0
32-0477	21.0
32-0478	21.0
32-0479	21.0
32-0480	24.0
32-0481	24.0
32-0482	21.0

**Aviation Fabricators
805 North Fourth Street
Clinton MO 64735**

Document No: AF-617
Revision: (B)
Date: October 1, 2019

32-0483	21.0
32-0484	22.5
32-0485	22.5
32-0486	21.0
32-0487	21.0

*Weights do not include cushions and upholstery

6.0 TOWING AND TAXIING

No change.

7.0 PARKING AND MOORING

No change.

8.0 PLACARDS AND MARKINGS

1. The following seat P/N's have Placard 15-0860 located on the underside of the seat base and must be installed in a FWD Facing position.

Fwd Facing Only Seat P/N's: 32-0436, 32-0437, 32-0442, 32-0443, 32-0456, 32-0457, 32-0458, 32-0459, 32-0460, 32-0461, 32-0462, 32-0463, 32-0464, 32-0465, 32-0466, 32-0467, 32-0468, 32-0469, 32-0470, 32-0471, 32-0472, 32-0473, 32-0474, 32-0475

VIEW LOOKING DOWN AT SEAT BASE

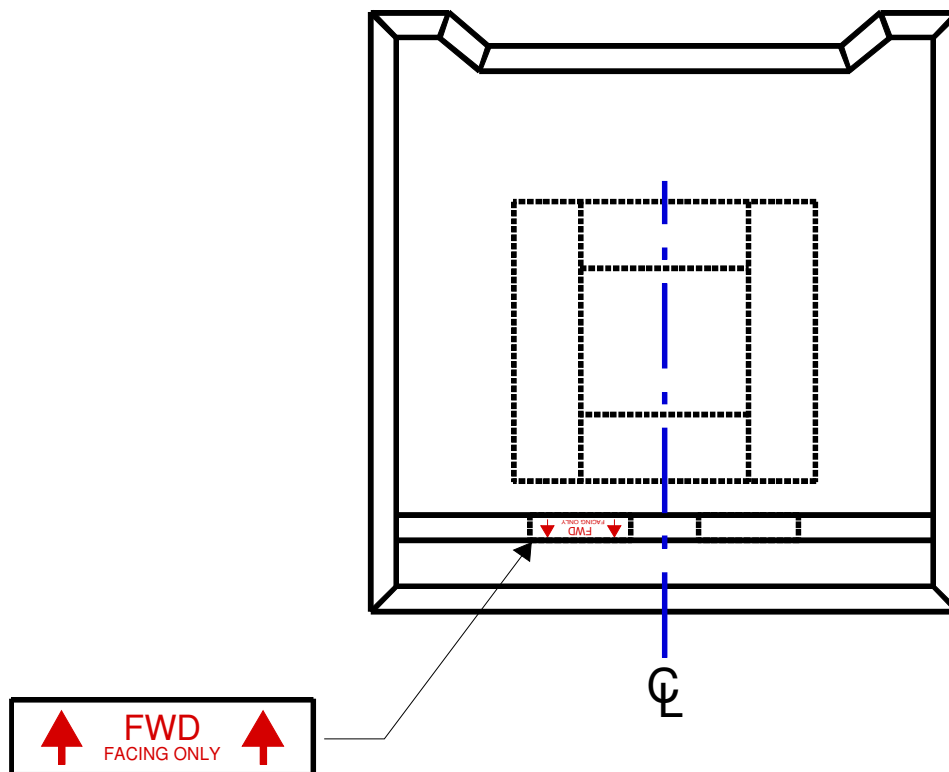

- The following seat P/N's have Placard 15-0870 located on the underside of the seat base and must be installed in a AFT Facing position.

Aft Facing Only Seat P/N's: 32-0450, 32-0451, 32-0452, 32-0453, 32-0476, 32-0477, 32-0478, 32-0479

VIEW LOOKING DOWN AT SEAT BASE

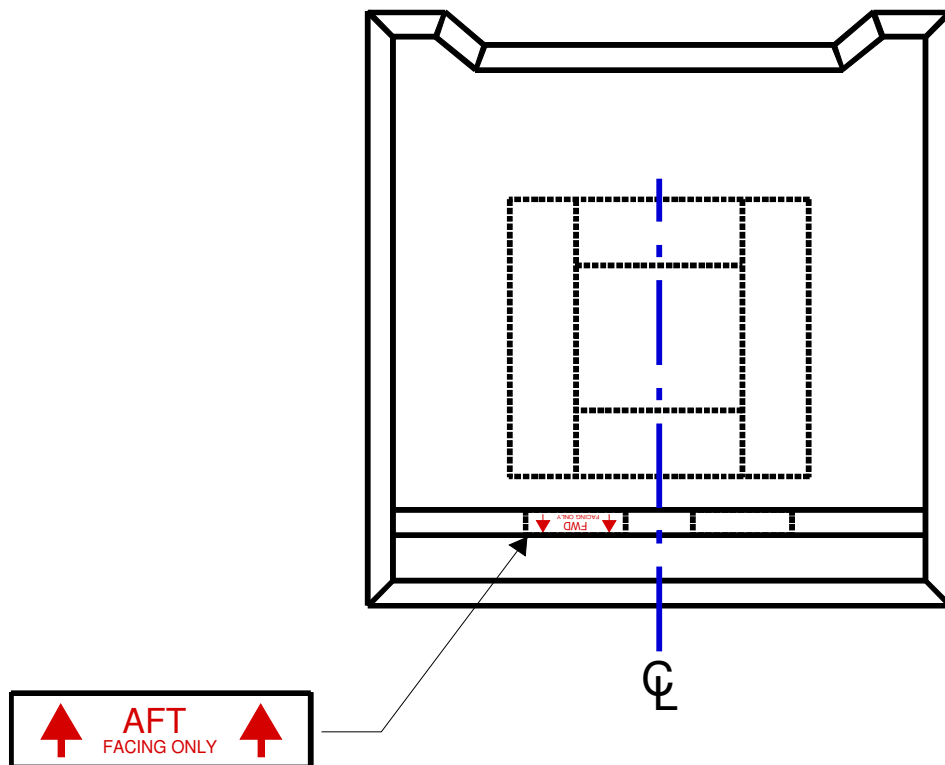

- Fwd/Aft Facing Seat P/N's: 32-0480, 32-0481, 32-0482, 32-0483, 32-0484, 32-0485, 32-0486, and 32-0487 and Aft Facing Only Seat P/N's 32-0450, 32-0451, 32-0452, 32-0453, 32-0476, 32-0477, 32-0478, 32-0479 require Placard 15-0883 to be installed on the aircraft sidewall in plain view of the seat occupant when the seats are installed in the aft facing position.

THE HEADREST MUST BE EXTENDED DURING TAXI, TAKEOFF, AND LANDING FOR AFT FACING SEATS

4. Seats with P/N 17-0983 Underseat Storage Bracket installed Placard P/N 15-0994 must be installed on the front of the bracket.

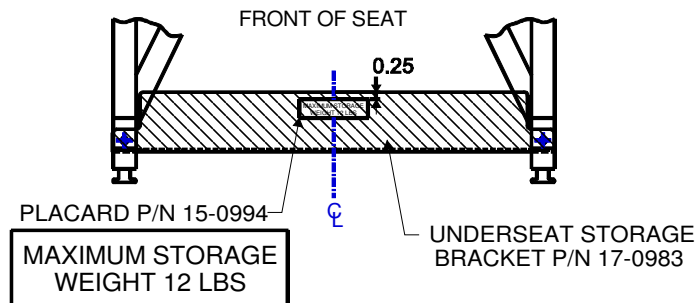

9.0 SERVICE INFORMATION

Typical Seat Service Instructions:

A. Upholstery Cleaning:

Seat Service Instructions

1. If possible remove seat back and seat bottom cushion assemblies from the seat frame assembly.
2. If possible dry clean fabric cushions.
3. If dry cleaning is not possible clean fabric with Armour All fabric cleaner or equivalent.
4. Clean leather with Armour All leather cleaner or equivalent.
5. Clean and inspect restraint system for damage, fraying, cuts or seam deterioration.
6. Inspect all attachment fittings and replace if necessary.
7. Inspect overall seat for fit and function.

Typical Seat Maintenance Instructions:

Seat Assembly

The high density seat is a self-contained complete assembly that mounts anywhere in the cabin to the existing seat track using standard fittings. Refer to Figures 1.0A and 1.0B.

Seat Installation

To install the high density seat on to the existing seat track, place seat assembly in proper location and lift hold down fitting keepers so that the studs will drop into the seat track. Move the seat assembly forward or aft to allow the keeper to lock into place on the seat track. Refer to Figure 1.0C.

Seat Removal

To remove the high density seat from the aircraft seat track lift each of the hold down fitting keepers and slide the stretcher forward or aft on the seat track so that the foot studs will be allowed to be lifted from the track.

Seat Belt & Shoulder Harness

Seat belt removal is accomplished by loosening attaching hardware and removing from the brackets on the seat assembly. Refer to Figures 1.0D, 1.0E, & 1.0J

Cushions

Seat bottom and seat back cushion assemblies are removed by simply pulling the cushion away from the Velcro on the seat bottom panel or up over the seat back assembly, respectively. The seat bottom and seat back cushions should weigh no more than 10 lbs each. All covering and upholstery materials must comply with 14 CFR 23.853 as stated on the installation instructions. Refer to Figure 1.0F for Cushion Assembly Reference.

Oxygen Dispensing Unit Availability

Per the installation instructions, the high density seat installation must comply with 14 CFR 23.1441. Each dispensing unit must be capable of being readily available to be placed into position on the face of the seat occupant.

B. RECOMMENDED OVERHAUL PERIODS

No additional overhaul time limitations.

10.0 AIRWORTHINESS LIMITATIONS

The Airworthiness Limitations section is FAA approved and specifies maintenance required under Sec. 43.16 and 91.403 of the Federal Aviation Regulations unless an alternative program has been FAA approved.

There are no Airworthiness Limitations to the aircraft with the addition of the high density seats installed by this STC.

11.0 TROUBLESHOOTING

Refer to the existing Aircraft Maintenance Manual for troubleshooting the seat installation that is required beyond the information found on the STC Data Lists: AF-151, AF-150, AF-149, and AF-148.

For replacement parts or repair of damage parts:

Contact Aviation Fabricators at (660) 885-8317.

Troubleshooting this installation should only be accomplished by FAA approved repair stations with the appropriate ratings or appropriately rated operator/individuals, with required test equipment and service data.